

## Value Added Services

Gough Econ has the ability to provide an entire material handling system between production and manufacturing. From bucket elevators to storage conveying systems they can move your product from A to B, efficiently and economically. Each system can be designed as a distribution system and include any means of conveyance and distributions from bucket elevators, belt conveyors, feeders, to lowerators, unloaders, storage conveyors, and controls.

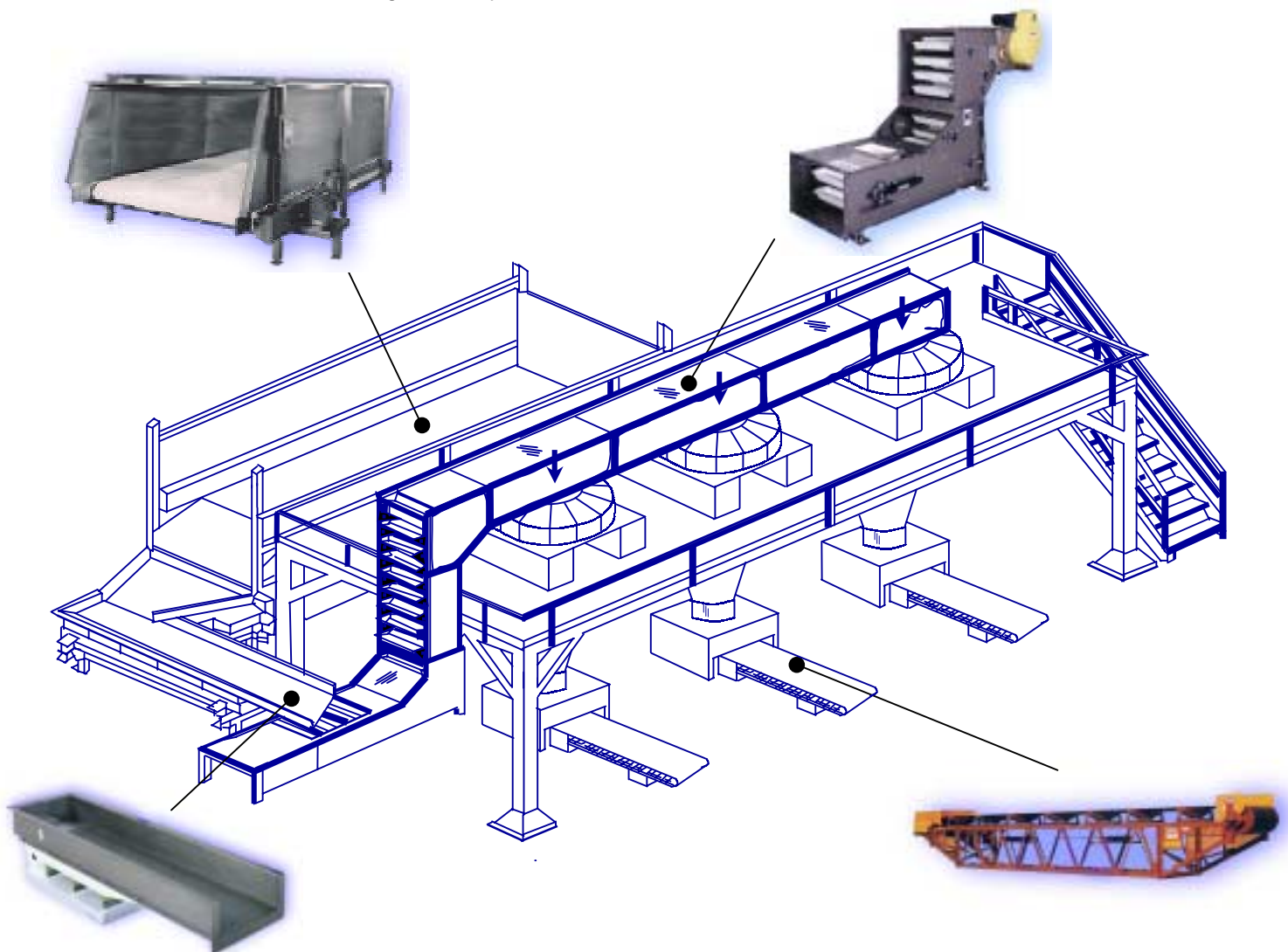

*Tough, Gentle, Clean*

**Gough Econ, Inc.**

P.O. Box 668583, Charlotte, NC 28266-8583  
Phone: 800.264-6844 Fax: 704.392.8706

E-Mail: [sales@goughecon.com](mailto:sales@goughecon.com)

Website: [www.goughecon.com](http://www.goughecon.com)

Form: valueadded.doc